

FEATURES

- 2 different configurable outputs: shutter channel (up to 1) and individual outputs (up to 2)
- Outputs suitable for capacitive loads, maximum 140 µF
- Supports KNX Data Security
- Manual output operation with push button and LED status indicator
- 10 logic functions
- Output timing
- 2 Master Light controls
- Total data saving on KNX bus failure
- Integrated KNX BCU (TP1-256)
- Dimensions 67 x 90 x 36 mm (2 DIN units)
- DIN rail mounting according to IEC 60715 TH35, with fixing clamp
- Possibility of connecting different phases in the outputs
- Conformity with the CE, UKCA, RCM directives (marks on the right side)

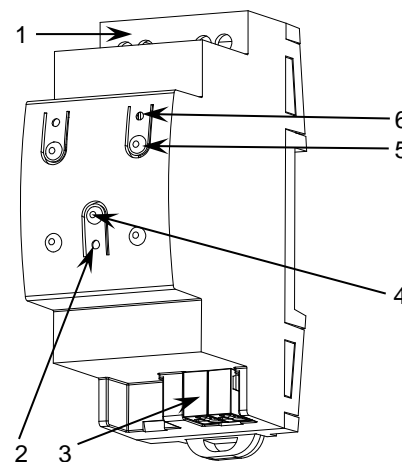

Figure 1: MINiBOX 20 v2

1. Outputs	2. Programming/test LED	3. KNX Connector
4. Programming/test button	5. Output control button	6. Output status LED indicator

Programming/Test button: short press to set programming mode. If this button is held while plugging the device into the KNX bus, it enters the safe mode. If this button is held for more than 3 seconds, the device enters the test mode. In order to perform a KNX Secure factory reset, while the device is in safe mode, press the button for 10 seconds until the programming LED changes its state.

Programming/Test LED: programming mode indicator (red). When the device enters the safe mode, it blinks (red) every half second. The manual mode is indicated by the green color. During the start-up (reset or after KNX bus failure) and if the device is not in safe mode, it starts a blue blinking sequence.

GENERAL SPECIFICATIONS

CONCEPT		DESCRIPTION		
Type of device		Electric operation control device		
KNX supply	Voltage (typical)	29 VDC SELV		
	Voltage range	21-31 VDC		
	Maximum consumption	Voltage	mA	mW
		29 VDC (typical)	3.8	110.2
24 VDC ¹	10	240		
Connection type		Typical TP1 bus connector for 0.8 mm Ø rigid cable		
External power supply		Not required		
Operation temperature		0 .. +55 °C		
Storage temperature		-20 .. +55 °C		
Operation humidity		5 .. 95%		
Storage humidity		5 .. 95%		
Complementary characteristics		Class B		
Protection class		II / III (4000 V)		
Operation type		Continuous operation		
Device action type		Type 1		
Electrical stress period		Long		
Degree of protection		IP20 / 2 (clean environment)		
Installation		Independent device to be mounted inside electrical panels with DIN rail (IEC 60715)		
Minimum clearances		Not required		
Response on KNX bus failure		Data saving according to parameterization		
Response on KNX bus restart		Data recovery according to parameterization		
Operation indicator		The programming LED indicates programming mode (red) and test mode (green). Each output LED indicates its status		
Weight		54 g		
PCB CTI index		175 V		
Housing material		PC FR V0 halogen free / 75 °C (housing) - 125 °C (connectors)		

¹ Maximum consumption in the worst-case scenario (KNX Fan-In model).

OUTPUTS SPECIFICATIONS AND CONNECTIONS		
CONCEPT	DESCRIPTION	
Number of outputs	2	
Output type / Disconnection type	Potential-free outputs through bistable relays with tungsten pre-contact / Micro-disconnection	
Rated current per output	AC 16(6) A @ 250 VAC (4000 VA) DC 7 A @ 30 VDC (210 W)	
Maximum load per output	Resistive	4000 W
	Inductive	1500 VA
Maximum inrush current	800 A/200 μ s 165 A/20 ms	
Different phases connection	Possibility of connecting different phases. It is not allowed to connect power supplies of different order, SELV with NO SELV, in the same block.	
Total maximum current in device	20 A	
Short-circuit protection	NO	
Overload protection	NO	
Connection method	Screw terminal block (0.5 Nm max.)	
Cable cross-section	0.5-4 mm ² (IEC) / 20-12 AWG (UL)	
Outputs per common	1	
Maximum response time	10 ms	
Mechanical lifetime (min. cycles)	3 000 000	

WIRING DIAGRAMS

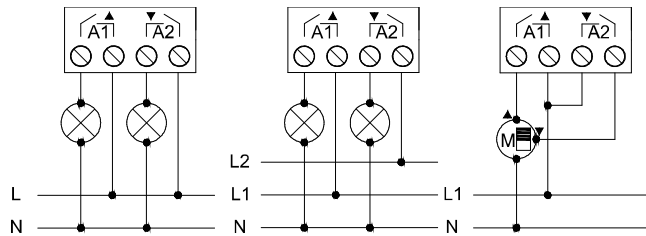
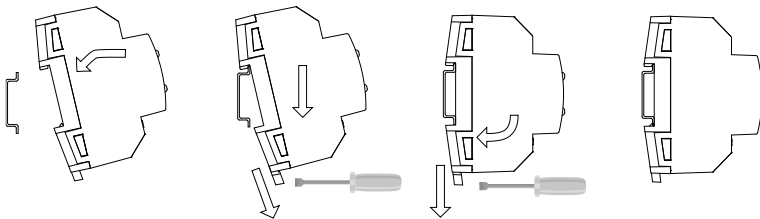

Figure 2: Wiring example (from left to right): 2 loads, 2 loads connected to different phases and shutter

⚠ In order to ensure the expected status of the relays, please check that the device is connected to the KNX bus before energizing the power circuit.

Attaching MINiBOX 20 v2 to DIN rail:



Removing MINiBOX 20 v2 from DIN rail:

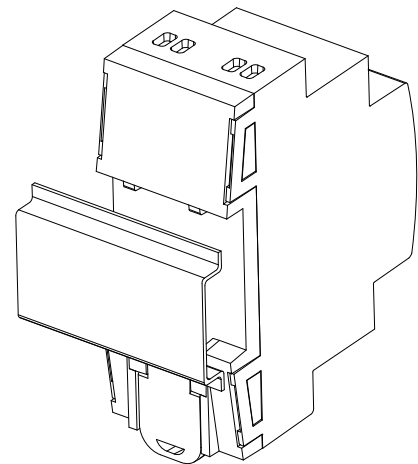
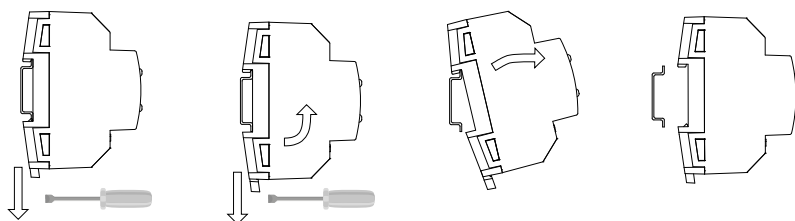

Figure 3: Mounting MINiBOX 20 v2 on DIN rail

⚠ SAFETY INSTRUCTIONS AND ADDITIONAL NOTES

- Installation should only be performed by qualified professionals according to the laws and regulations applicable in each country.
- Do not connect the mains voltage nor any other external voltage to any point of the KNX bus; it would represent a risk for the entire KNX system. The facility must have enough insulation between the mains (or auxiliary) voltage and the KNX bus or the wires of other accessories, in case of being installed.
- Once the device is installed (in the panel or box), it must not be accessible from outside.
- Keep the device away from water (condensation over the device included) and do not cover it with clothes, paper or any other material while in use.
- The WEEE logo means that this device contains electronic parts and it must be properly disposed of by following the instructions at <https://www.zennio.com/en/legal/weee-regulation>.
- This device contains software subject to specific licences. For details, please refer to <http://zennio.com/licenses>.